

# MOD 102+ GUITAR AMP KIT (K-MOD102+)

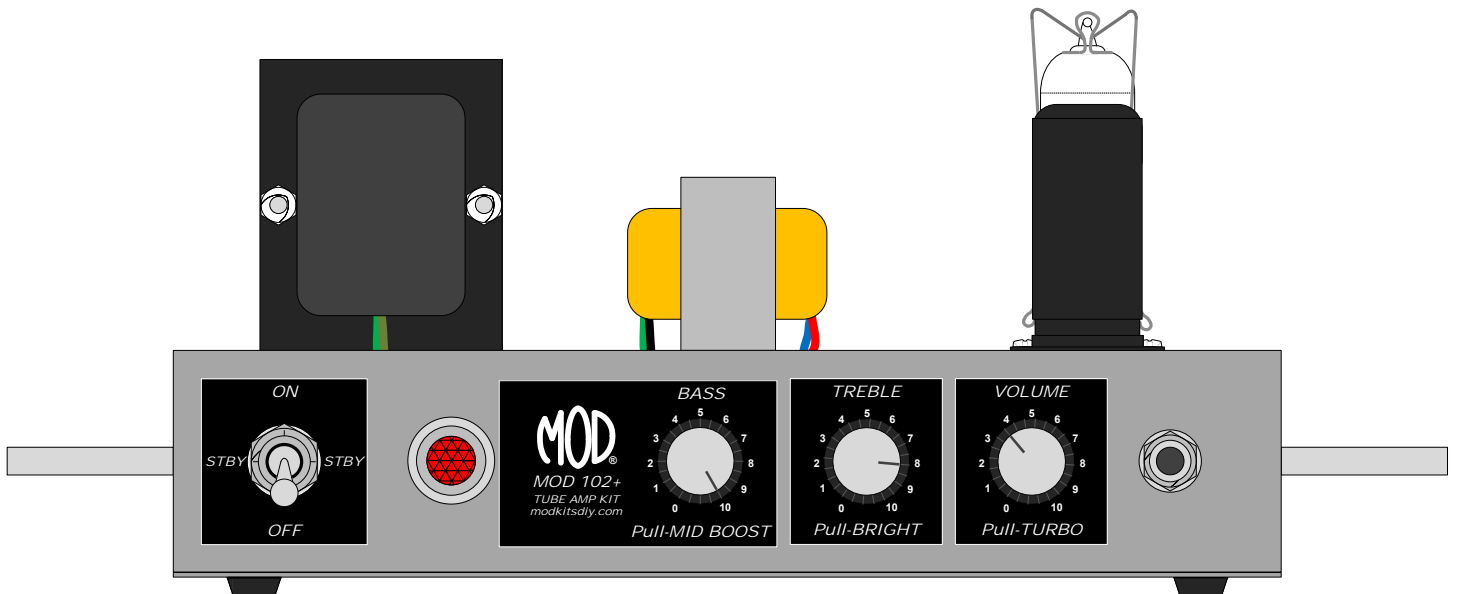

## Use these instructions to learn:

- How to build a tube amp.

This tube guitar amplifier circuit is based on a classic American circuit design combined with a British style class A output section. At low volume it produces a clean chimey tone that moves into smooth overdrive at higher volumes.

+ features include a three position progressive toggle switch for off-standby-power and additional push-pull functionality for each control:

- Pull out the bass control knob for “mid boost.”
- Pull out the treble control knob for “bright.”
- Pull out the volume control knob for “turbo.”

# MOD<sup>®</sup>

[www.modkitsdiy.com](http://www.modkitsdiy.com)

## **TABLE OF CONTENTS**

TOOL LIST .....	3
PARTS LIST .....	4
SAFETY .....	5
SOLDERING TIPS .....	6
WIRING TIPS .....	7
HARDWARE FASTENING TIP .....	8
STEP BY STEP ASSEMBLY INSTRUCTIONS .....	8
Section 1 - Mounting of Top Components .....	8
Section 2 - Mounting of Front Components .....	10
Section 3 - Mounting of Rear Components .....	11
Section 4 - Mounting Terminal Strips and Components .....	11
Section 5 - Connect Rear Mounted Components .....	15
Section 6 – Connect the Tube Filament Wiring .....	16
Section 7 – Finishing Up .....	16
Label Mounting Instructions .....	18

### **PARTS LIST DRAWINGS** (4)

There are four parts list drawings separated from these instructions to help you find and identify each part.

### **ASSEMBLY DRAWINGS** (8)

There are eight assembly drawings separated from these instructions to help you with each step of the assembly.

## **MOD 102 GUITAR AMP KIT – BACKGROUND**

The MOD 102+ Guitar Amp Kit was designed for anyone who is interested in building their own tube guitar amplifier head.

It is meant for practice amp volume (up to 8 Watts). It has an 8 ohm output impedance. (We recommend using it with a speaker cabinet that has an overall power handling of at least 10W). Use 16 AWG speaker cable to connect from the amplifier to your speaker cabinet.

The web-site [www.modkitsdiy.com](http://www.modkitsdiy.com) has been set up to help answer your questions after you have thoroughly read through the entire set of instructions.

## **TOOL LIST**

- Wire Strippers
- Needle Nose Pliers
- Cutting Pliers
- Desoldering Pump
- Solder (60/40 rosin core)
- Soldering Station
- Phillips Head Screwdrivers
- Slotted tip screwdrivers (3mm tip)
- Digital Multimeter (DMM)
- Alligator Clip Test Leads (to fit DMM)
- Channellock Pliers (or similar type)
- Miniature Round File (fine cut)

## PARTS LIST

Please see the parts list drawings for help with finding and identifying each part along with corresponding part numbers.

### **RESISTORS:**

<u>Description</u>		<u>Quantity</u>
100Ω	1W	3
150Ω	5W	1
470Ω	1W	1
1.5kΩ	1/2W	2
5.6kΩ	1/2W	1
6.8kΩ	1/2W	1
10kΩ	1/2W	1
10kΩ	1W	1
100kΩ	1/2W	3
220kΩ	1/2W	1
220kΩ	1W	1
470kΩ	1/2W	1
1MΩ	1/2W	1

### **TERMINAL STRIPS:**

<u>Description</u>	<u>Quantity</u>
5 lug terminal strip (1 <sup>st</sup> lug common)	3
5 lug terminal strip (3 <sup>rd</sup> lug common)	1
7 lug terminal strip (1 <sup>st</sup> & 7 <sup>th</sup> lug common)	1
2 lug terminal strip (2 <sup>nd</sup> lug common)	1

### **TRANSFORMERS:**

<u>Description</u>	<u>Quantity</u>
Power Transformer 269EX	1
Output Transformer P-T31	1

### **CAPACITORS:**

<u>Description</u>		<u>Quantity</u>
150pF	500V	1
250pF	500V	1
.022μF	400V	1
.047μF	400V	2
.1μF	400V	1
22μF	50V	2
47μF	350V	3
100μF	100V	1

### **HARDWARE:**

<u>Description</u>	<u>Quantity</u>
#8 self-tap screws	4
#6 screws	13
#6 hex nuts	13
#6 lock washers	6
#4 screws	4
#4 hex nut	4
3/8" lock washers	5

### **TUBES:**

<u>Description</u>	<u>Quantity</u>
12AX7/ECC803	1
6BQ5/EL84	1

### **MISCELLANEOUS PARTS:**

<u>Description</u>	<u>Quantity</u>
Solid state diode 1N4007	2
250kΩ audio push-pull pot	2
1MΩ audio push-pull pot	1
knobs	3
Input jack (switched)	1
output jack	1
9 pin miniature tube socket	2
preamp tube shield	1
EL84 tube retainer	1
Rubber Grommet (3/8" center)	4
Rubber Grommet (1/4" center)	1
red jewel	1
Power switch (3 pos. prog.)	1
1A fuse	1
Fuse holder	1
Light bulb	1
Lamp holder	1
Handle with mounting hardware	2
Rubber bumpers	4
Power cord	1
Steel chassis box and cover	1/each
Labels	1 set
Green 20 AWG wire	4 feet
White 20 AWG wire	6 feet
Black 22 AWG wire	1 foot

Visit [www.modkitsdiy.com](http://www.modkitsdiy.com) and e-mail [info@modkitsdiy.com](mailto:info@modkitsdiy.com) if you have any problems when first turning on your amp for troubleshooting help. *If you smell or see smoke, hear something pop, or the chassis becomes too hot to touch, turn off power and unplug immediately.*

## SAFETY

Tube amps operate at high voltages that have the potential to injure and kill. Please remember the following when working on this project.

- Only work on the amp when you are wide awake and sober.
- Do not plug the amp in until you have gone through all of the instructions, checking and re-checking each step.
- Do not turn the amp on until you have connected it to a speaker cabinet.
- Be aware that tubes become very hot when the amp is on and can take up to 10 minutes to cool down after power is turned off.
- Work in a ventilated area when soldering.
- Always follow the one hand rule when working with an amp that is connected to power or may have voltage present. *(Any amp that has been plugged in at one time, may have high voltage present).*

**The one hand rule** (pictured below): is a safety precaution for working on an amp that is plugged in or could potentially have high voltages present. Using alligator clips with your DMM, clip the ground side to the chassis and use the other side to probe at various test points with one hand. *This prevents a fatal shock which can result from current passing through the heart.* *(Many people even put their other hand in their pocket or behind their back).*

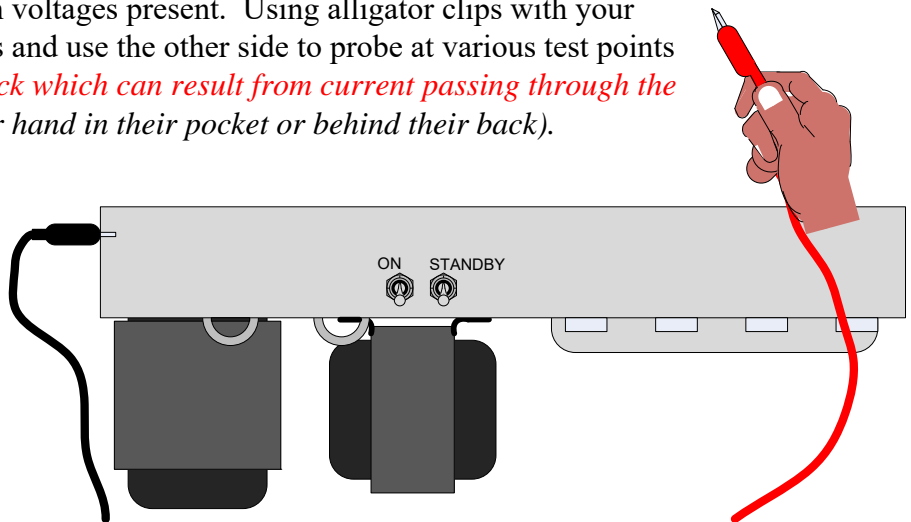

Always probe the amp for dangerous voltages at several test points before working on it, even if it has been turned off and unplugged for months.

### Test points include:

- Each positive end of polarized filter caps



## SOLDERING TIPS

It is important to make a good solder joint at each connection point. A cold solder joint is a connection that may look connected but is actually disconnected or intermittently connected. (A cold solder joint can keep your project from working.)

Follow these tips to make a good solder joint. *Take your time with each connection and make sure that all components are connected and will remain connected if your project is bumped or shaken.*

1. Bend the component lead or wire ending and wrap it around the connection point.
  - Make sure it is not too close to a neighboring component which could cause an unintended connection.
2. Wrap the component lead so that it can hold itself to the connection point.
3. Touch the soldering iron to both the component lead and the connection point allowing both to warm up just before applying the solder to them.
4. Be sure to adequately cover both component lead and connection point with melted solder.
  - Remove the soldering iron from your work and allow the solder joint to cool. (The solder joint should be shiny and smooth after solidifying.)
  - Cut off any excess wire or component leads with cutting pliers.
  - Clean the soldering iron's tip by wiping it across the wet sponge again after making the solder joint.

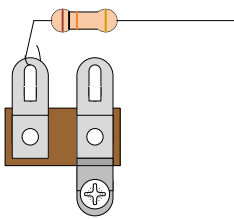

1. Bend the component lead and wrap it around the connection point.

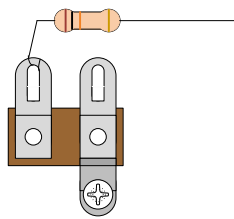

2. Wrap the component lead so that it can hold itself to the connection point.

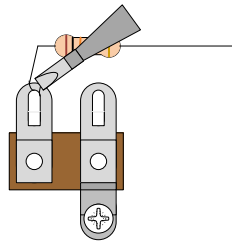

3. Heat up both component lead and connection point with the soldering iron.

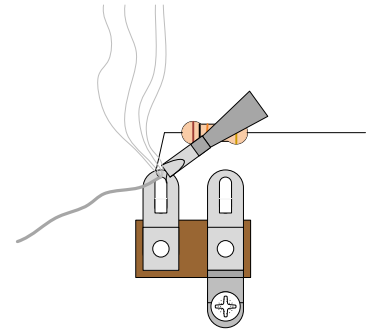

4. Apply solder to both component lead and connection point.

### De-Soldering Tip

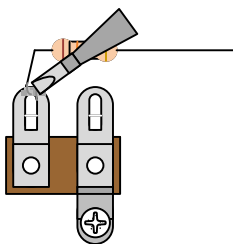

1. Heat up old solder joint with the soldering iron.

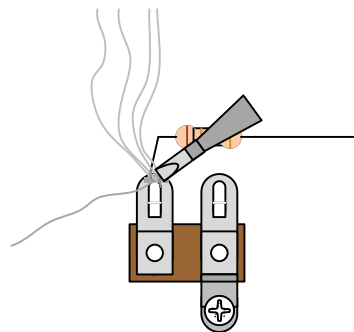

2. Apply fresh solder to mix in with old solder joint

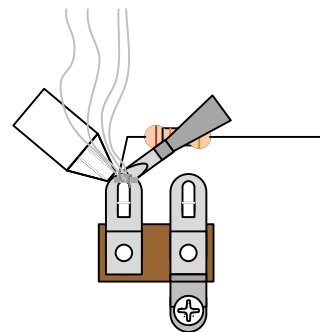

3. Use a de-soldering tool to remove the old solder joint while it is heated.

## WIRING TIPS

- Because of the electro-magnetic properties of current traveling through a wire, there are wiring conventions used when making wire connections.

A) Twist the wires together where indicated in the instructions.

B) If two wire paths intersect, try to have them cross over each other as perpendicular as possible. (You should follow the path of the wires shown in the instructions).

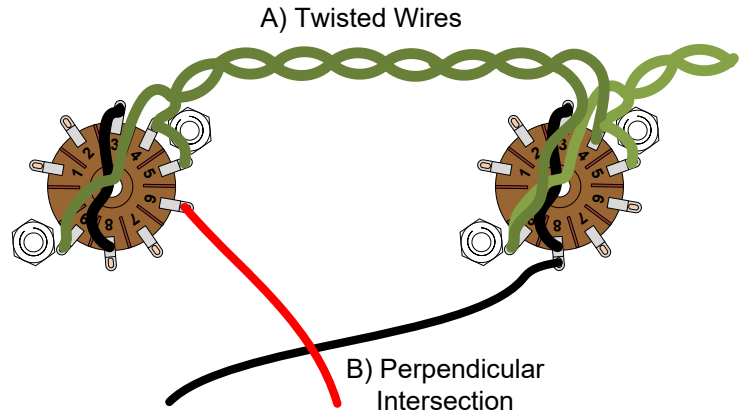

- Measure the wire by running it along its actual path (shown in the drawings) and then cutting it with your wire cutters at a length that will give it a little bit of slack after stripping off the insulation and soldering.

*It is important not to make the wires too long.*

- Be careful not to burn the insulation of nearby wires with the soldering iron.
- With the terminal strips used in this kit, you might want to connect some wires to the lower holes and components to the upper holes. (Doing this can make it easier to change components for modification).

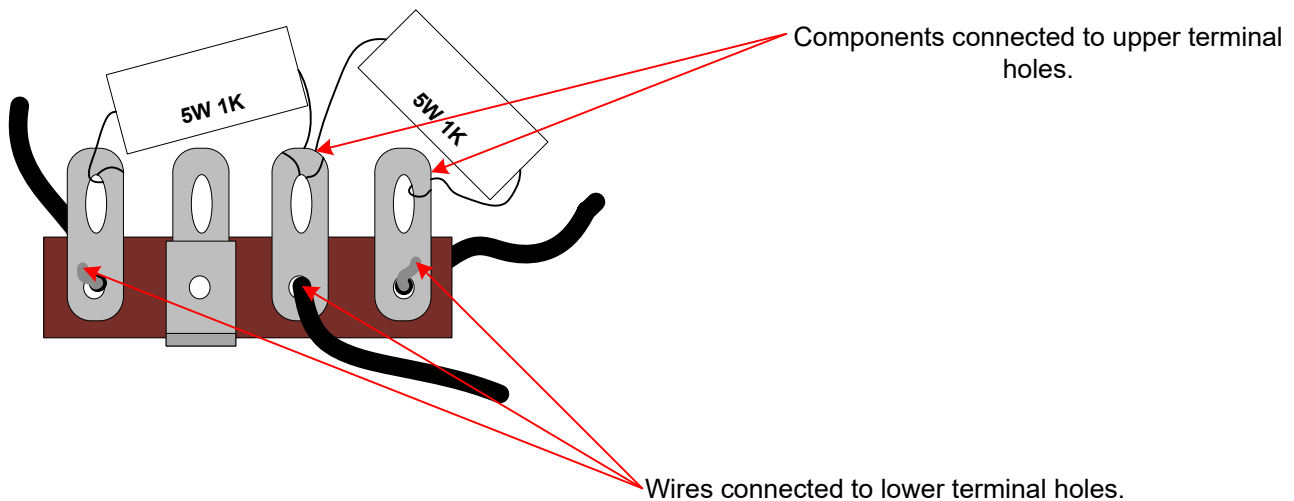

## HARDWARE FASTENING TIP

When fastening components with mounting hardware (screws, lock washers, and hex nuts), the lock washer and hex nuts should be fastened on the other side of the chassis from the head of the screw in the order pictured below.

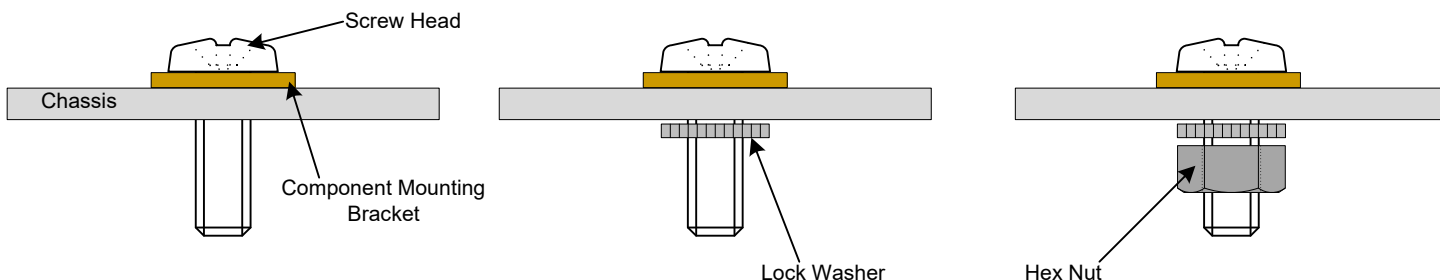

## STEP BY STEP ASSEMBLY

Please refer to the respective drawings for each section. *We recommend browsing over the instructions and looking at all drawings once before actually beginning to assemble the kit.*

### SECTION 1 – Mounting of Top Components

Please refer to **Drawings 1 – 3**.

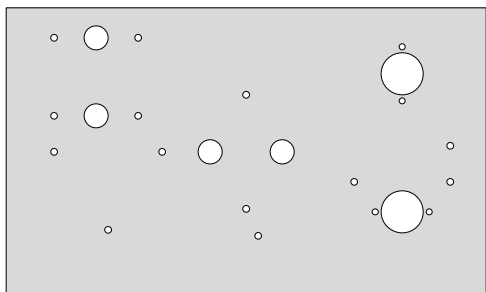

Find your chassis box. **Drawing 1** identifies the names of components that you will be mounting to the top of the chassis box.

#### Before you begin!

Use a fine cut miniature round file to carefully file away the paint coating only from the inside edge of each chassis hole.

*(The chassis provides the ground connection for many components so it is important that the inner edge of these holes are not insulated by the paint coating).*

#### Step 1 – Mount the Labels

Follow the label mounting instructions on page 18 and attach each label over its corresponding chassis hole.

#### Step 2 – Mount the rubber grommets with the 3/8" centers

**Drawing 2** shows where to mount these four rubber grommets. Squeeze the grommet into the hole and push it into place with your fingers.



#### Step 3 – Mount the 9 pin miniature tube socket for the 12AX7 with its tube shield

**Drawing 2** shows where to mount the 9 pin miniature socket “V1”. Make sure that pins 1 & 9 face the front of the chassis. Use #4 hardware and the tube shield to mount this socket.

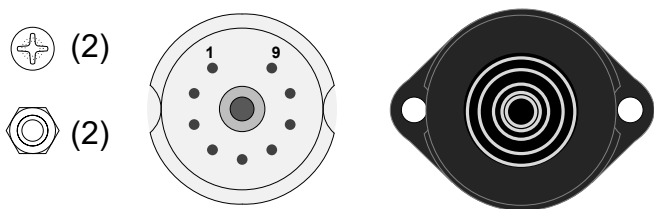

**Tip:** Because the tube shield mounting holes are very close to the socket edge, it may be easiest to fasten the first screw loosely and then the second screw by holding the hex nut (flat side to socket edge) against the chassis holes and then inserting the screw from the top of the chassis. Finish up by fastening both screws tightly.

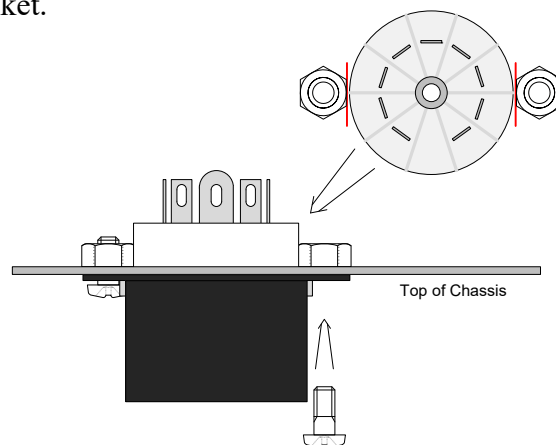



Step 4 – Mount the 9 pin miniature tube socket with its retainer for the EL84

**Drawing 2** shows where to mount the 9 pin miniature socket “V2” and its retainer. Make sure that pins 1 & 9 face the “TR1” side of the chassis. (Use #4 hardware).

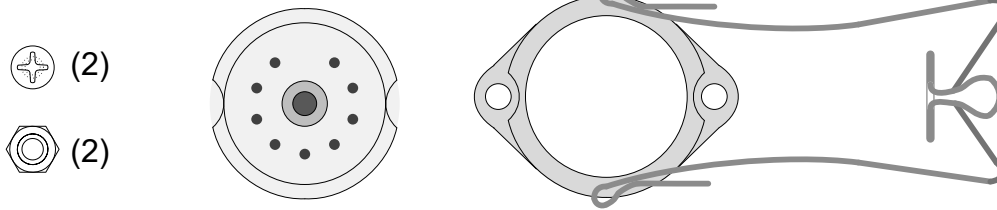

Step 5 – Mount both side handles

Mount both handles to the sides of the chassis box using their supplied #8 hardware. (Doing this step now will help you flip the chassis when mounting the two transformers).

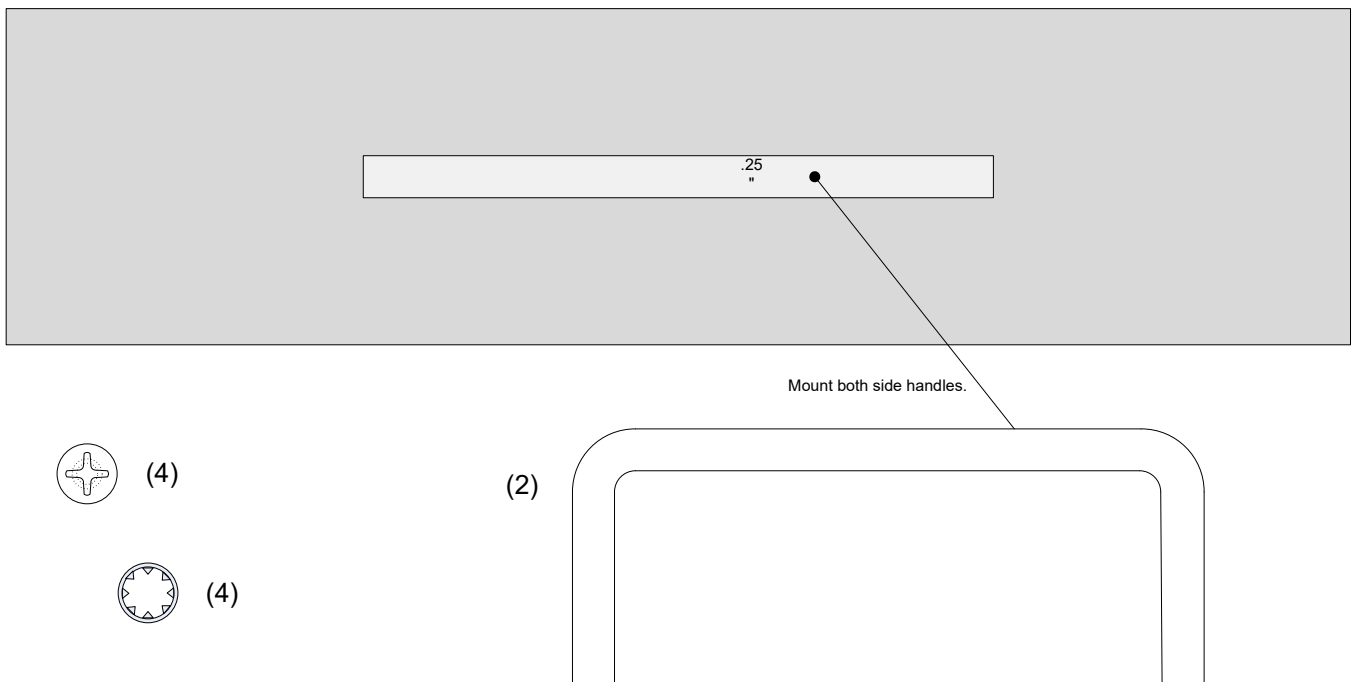

Step 6 – Mount the Power Transformer (TR1)

Remove the 269EX power transformer from its packaging. **Drawings 2 & 3** show where to mount the power transformer.

- A) Cut off the gray wire as described on the drawing.
- B) Place the transformer on its side and push the wires (one at a time) through their respective grommet holes as indicated on the drawing.
- C) Slowly tilt the transformer upright so that the mounting holes line up with the transformer feet, while continuing to push each bundle of wires through the grommet holes. (Be careful not to dislodge the rubber grommets).
- D) Use #6 mounting hardware to fasten the power transformer in place.

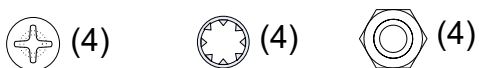

### Step 7 – Mount the Output Transformer (TR2)

**Drawing 3** shows where to mount the output transformer P-T31.

A) Hold the transformer up above the chassis and push the wires through their respective grommet holes as indicated on the drawing.

B) Place the transformer on the chassis so that the mounting holes line up with the transformer feet.

C) Use #6 mounting hardware to fasten the power transformer in place.



## SECTION 2 – Mounting of Front Components

Please refer to **Drawing 4**.

### Step 1 – Mount the Lamp Holder

**Drawing 4** shows where to mount the lamp holder. Be sure to mount it so that its solder lugs point towards the bottom opening of the chassis box. (Once the lamp holder is mounted you may screw in the bulb and then the jewel).

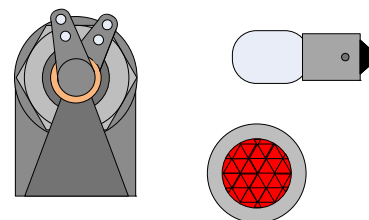

### Step 2 – Mount the Power Switch

**Drawing 4** shows where to mount the power switch. Be sure to mount the power switch with its solder lugs directed toward the bottom opening of the chassis box.

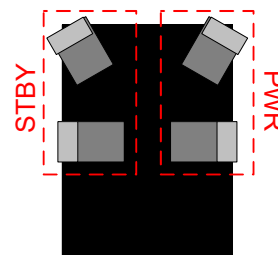

### Step 3 – Mount the Controls

**Drawing 4** shows where to mount the bass, treble, and volume pots.

#### Treble and Bass:

- Remove the two nuts and two flat washers from the 250K Bass and Treble pot bushings. On each pot put one nut on the bushing, turning it all the way down on the bushing.
- Put one of the 3/8" lock washers on the bushing, then mount the pot to the front panel with all lugs facing up.
- Place one of the flat washers on the bushing followed by the remaining mounting nut and tighten. (Keep the remaining flat washers as one will be used in the next step).

#### Volume:

- Remove the nut from the bushing leaving the black lock washer on the bushing.
- Bend back the small mounting tab on the side of this pot so that it does not interfere with mounting.
- Put one of the 3/8" lock washers on the bushing and mount the pot to the front panel with its solder lugs facing up.
- Put one of the flat washers from the previous step on the bushing followed by the nut, and tighten.

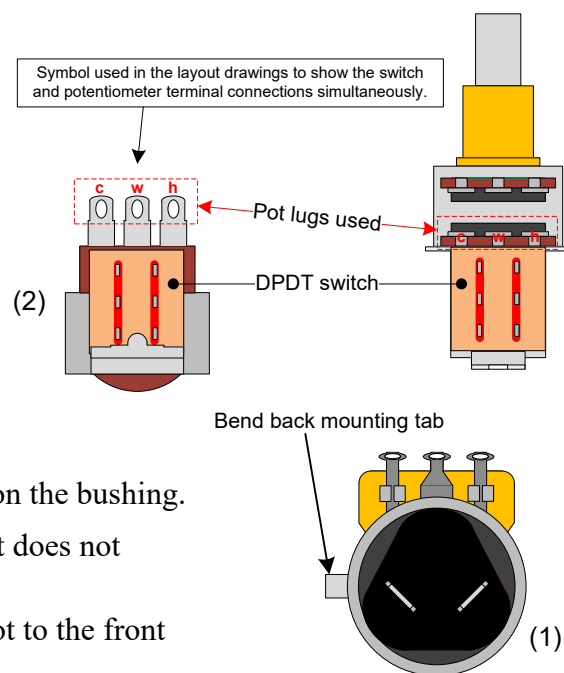

When all three pots are mounted, turn their shafts all the way counter-clockwise. (Once you have done this, you can mount the knobs while pointing to “0” and tightening their set screws).

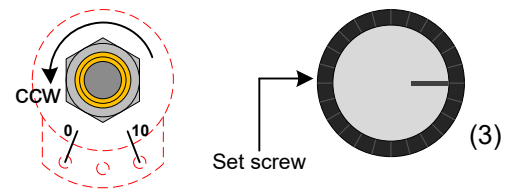

**Step 4 – Mount the Input Jack**

**Drawing 4** shows where to mount the input jack.

- Remove the nut and flat washer from the input jack.
- Put one of the 3/8" lock washers on the jack bushing and mount it to the front panel with the middle (“shunt”) lug facing up.
- Put the flat washer and nut on the bushing and tighten.

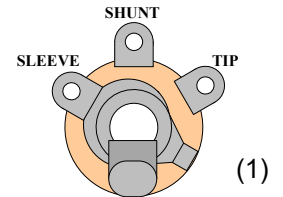

**SECTION 3 – Mounting of Rear Components**

Please refer to **Drawing 4**.

**Step 1 – Mount the Output Jack**

**Drawing 4** shows where to mount the output jack.

- Remove the nut and flat washer from the input jack.
- Put the remaining 3/8" lock washers on the jack bushing and mount it to the rear panel with the solder lugs facing up.
- Put the flat washer and nut on the bushing and tighten.

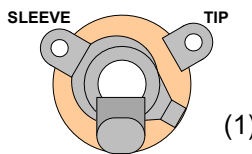

**Step 2 – Mount the Fuse Holder**

**Drawing 4** shows where to mount the Fuse holder. You can also insert the 1A fast blow fuse at this time.

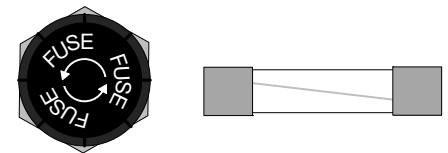

**SECTION 4 – Mounting Terminal Strips and Components**

Please refer to **Drawings 5 & 6**.

**Step 1 – Mount the Terminal Strips**

**Drawing 5** shows what you should see when you flip the chassis box over so that you are looking inside and viewing from the rear side with the terminal strips in place. The terminal strips are labeled T1 – T6. (You will be mounting all 6 terminal strips in this step).

Use #6 hardware and **Drawing 5** to mount the 6 terminal strips in the same orientation as in the drawing.

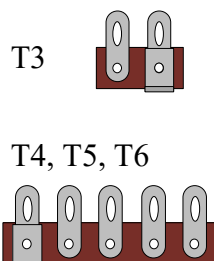
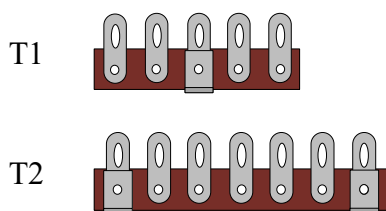

**Note:** Terminal strip terminals are numbered from left to right with mounting bracket directed towards the viewer and will be referred to with T6(3) meaning terminal number 3 on “T6”.

## Step 2 – Solder Components to Their Terminal Strip Locations

Please see page 6 “Soldering Tips” if you are new to making solder connections.

**Drawing 6** shows each component and its respective location on the terminal strip. *Be sure to follow the same orientation of polarity as shown in the drawing for diodes and polarized electrolytic capacitors.*

These instructions will walk you through the mounting of each component so that no components are missing. Unless noted otherwise, cut the component leads to a reasonable mounting length, wrap the leads around their connection points and solder. Be sure to leave room on each terminal for the mounting of future components. You can use Assembly **Drawing 8** to anticipate what other components and wires will be mounted to a particular location.

### **Connect wires to filter caps:**

When connecting the wire, you want to strip about ¼” of insulation off of each end to wrap around terminals. For these wires consider mounting to the lower terminal holes to leave more room for resistor and capacitor connections on T1 and T2.

- 1) Connect a 1 ½" length of white wire from T1(3) to T1(1).
- 2) Connect a 1 ½" length of white wire from T1(3) to T1(5).
- 3) Connect a 2" length of white wire from T1(2) to T2(3).
- 4) Connect a 3" length of white wire from T1(4) to standby/power switch lug 1.
- 5) Connect a 5" length of white wire from T2(5) to standby/power switch lug 2.

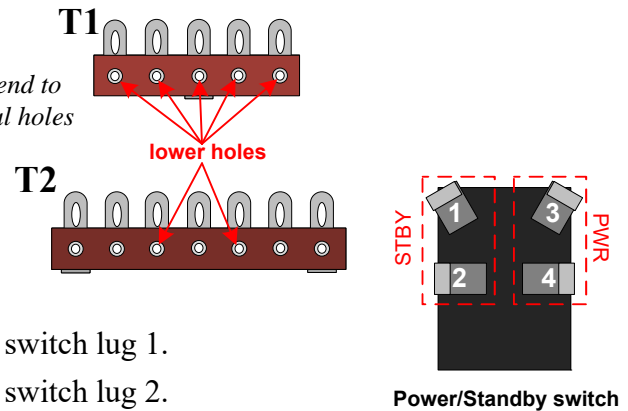

### **Mount the three filter caps:**

- 1) One 47  $\mu$ F (350V) cap is soldered with negative end to T1(5) and positive end to T2(5).
- 2) The next 47  $\mu$ F (350V) cap is soldered with negative end to T1(1) and positive end to T2(2).
- 3) The remaining 47  $\mu$ F (350V) cap is soldered with negative end to T1(3) and positive end to T2(3).

### **Mount the three 100 $\Omega$ resistors to T1:**

- 1) Connect a 100  $\Omega$  resistor from T1(2) to T1(4).
- 2) Connect another 100  $\Omega$  resistor from one of the lamp holder solder lugs to T1(3), the ground lug of T1.
- 3) Connect the remaining 100  $\Omega$  resistor from the other lamp holder solder lug to T1(3).

### **Connect T2 components:**

- 1) Connect one diode with the anode to T2(4) and cathode to T2(5).
- 2) Connect the other diode with the anode to T2(6) and cathode to T2(5).
- 3) Connect the 220K 1W resistor from T2(5) to T2(7)
- 4) Connect the 10K 1W resistor from T2(2) to T2(3)
- 5) Connect the 470K resistor from T2(2) to T2(1)

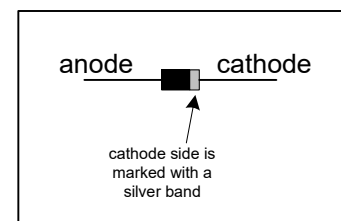

## Connect the T3 and bass pot components:

The bass and treble controls are dual 250K pots with a DPDT push-pull switch attached. The front pot section, closest to the front panel, will not be used. The DPDT lug numbering is shown in the drawings.

1) Connect the 6.8K resistor from the bass pot's c-lug ("cold" lug) to mid-boost switch lug 2, but **do not solder either connection point, yet.**

*Tip: When making the capacitor connections at this pot, it is important that the leads do not accidentally touch the pot/switch body or a different lug than intended. If you feel it is necessary to insulate the capacitor leads, you might consider doing so by stripping some of the insulation from the black 22 AWG wire and sliding it over the capacitor leads.*

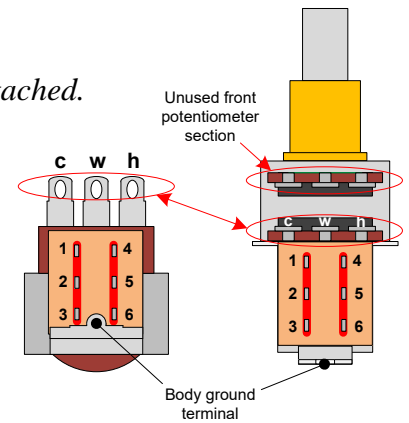
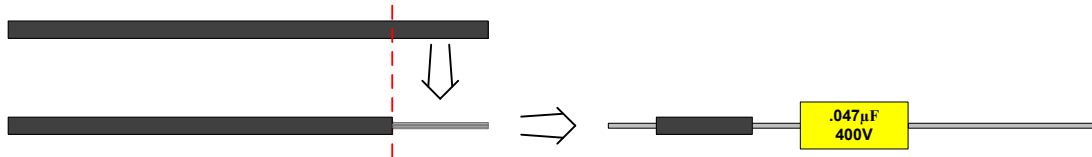

2) Connect the .047  $\mu\text{F}$  cap from the bass pot's c-lug to T3(1). Now, solder these connections.

3) Connect one lead of the 10K,  $\frac{1}{2}$  watt resistor to mid-boost switch lug 2 and connect the other lead to both mid-boost switch lug 3 and the body ground terminal. Now, solder these connections.

4) Connect the .1  $\mu\text{F}$  cap from T3(1) to the bass pot's w-lug ("wiper" lug), but **do not solder at the w-lug, yet.**

5) Connect a 2" piece of white wire from the bass pot's w-lug to the treble pot's c-lug. Now, solder these connections.

6) Connect a 100K resistor from T3(1) to T4(5).

## Connect the treble pot components:

1) Connect a 2  $\frac{3}{4}$ " piece of white wire from the treble pot's w-lug to the volume pot's h-lug ("hot" lug). **Do not solder these connections, yet.**

2) Connect a 150 pF capacitor from the treble pot's w-lug to bright switch lug 4. Solder all connections now.

3) Connect the 250 pF capacitor from the treble pot's h-lug to T4(5).

*Tip: The black 22 AWG stranded wire is supplied because the white solid-core wire is too thick to fit through the switch lugs. Normally, it's a good idea to strip and tin  $\frac{1}{4}$ " at the stranded wire ends before making the connections. In this case, on the end that will connect to the switch lug, just strip  $\frac{1}{8}$ " and do not tin that end.*

4) Connect a 2" piece of black 22 AWG wire from bright switch lug 5 to the volume pot's wiper lug. **Do not solder the wiper lug connection, yet.**



### Connect the volume pot and input jack components:

- 1) Connect a 3" piece of white wire from the volume pot's cold lug to the input jack's sleeve lug, but **do not solder at the sleeve lug, yet.**
- 2) Connect a 1 ½" piece of white wire from the volume pot's hot lug to turbo switch lug 1.
- 3) Connect a 2 ½" piece of white wire from the volume pot's wiper lug to V1 tube socket's pin 7. **Solder all connections, now.**
- 4) Connect one end of the 1MΩ resistor to both the "sleeve" and "shunt" lugs of the input jack. Connect the other end to the input jack's "tip" lug, but **do not solder at the "tip" lug, yet.**
- 5) Connect the 33kΩ resistor from the input jack's "tip" lug to V1 tube socket's pin 2.

### Connect T4 and V1 components:

- 1) Connect a 2 ¼" piece of white wire from T4(5) to V1 pin 1. *Consider using the lower terminal hole.*
- 2) Connect a 2 ½" piece of white wire from T4(3) to V1 pin 3. *Consider using the lower terminal hole.*
- 3) Connect a 5 ½" piece of white wire from T2(2) to T4(4), **but do not solder at T4, yet.** *Consider using the lower terminal hole.*
- 4) Connect a 3 ½" piece of white wire from T4(4) to T6(5). Now, solder at T4(4), but **do not solder at T6(5), yet.** *Consider using the lower terminal hole.*
- 5) Connect a 100kΩ resistor from T4(5) to T4(4).
- 6) Connect the remaining .047 μF cap from T4(5) to turbo switch lug 2.
- 7) Connect a 22μF cap with the negative (-) end to T4(1) and positive (+) end to T4(3).
- 8) Connect a 1.5kΩ resistor from T4(1) to T4(3).

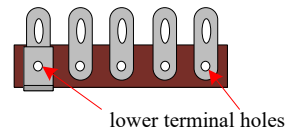

### Connect T5 and V1 components:

- 1) Connect a 2" piece of white wire from T6(5) to T5(2). Solder both connections. *Consider using the lower terminal hole.*
- 2) Connect a 2" piece of white wire from T5(1) to T5(5). *Consider using the lower terminal hole.*
- 3) Connect a 1 ½" piece of white wire from T5(3) to V1 pin 6.
- 4) Connect the remaining 22μF cap with the negative (-) end to T5(5) and positive (+) end to V1 pin 8, but **do not solder at pin 8, yet.**
- 5) Connect the remaining 1.5kΩ resistor from T5(5) to V1 pin 8. Now, solder all connections.
- 6) Connect the remaining 100kΩ resistor from T5(2) to T5(3).

**Connect T6 and V2 components:**

- 1) Connect the 470 $\Omega$  resistor from T6(5) to V2 pin 9.
- 2) Connect the 5.6k $\Omega$  resistor from T6(3) to V2 pin 2.
- 3) Connect the .022 $\mu$ F cap with from T6(3) to T5(3).
- 4) Connect the remaining 220k $\Omega$  resistor from T6(3) to T6(1).
- 5) Connect the 150 $\Omega$ , 5 watt resistor from T6(1) to V2 pin 3, but **do not solder at pin 3, yet.**
- 6) Connect the 100 $\mu$ F cap with negative end to T6(1) and positive end to V2 pin 3. Solder all connections.

**Connect the transformer wires:**

*Tip: Before connecting transformer wires, measure the best wire length by running the wire along its actual path (as shown in the drawings) and then cut it with your wire cutters at a length that will give it a little bit of slack after stripping off the insulation and soldering. (It's important not to make the wires too long).*

- 1) Intertwine TR1's two green wires and connect one to each of the two solder lugs on the lamp holder. (It doesn't matter which green wire connects to which lug, just don't connect them to the same lug). Leave room at each terminal on the lamp holder for a future wire connection from the lamp holder to the tube filaments.
- 2) Connect TR1's white wire to power switch lug 3.
- 3) Connect TR1's red/yellow wire to T2(1).
- 4) Connect one of TR1's red wires to T2(4) and its other red wire to T2(6).
- 5) Connect TR2's red wire to T2(3).
- 6) Connect TR2's blue wire to V2 pin 7.

**SECTION 5 – Connect Rear Mounted Components**

**Drawing 7** shows the inside of the chassis as viewed from the front looking at the rear.

**Connect to the output jack and fuse holder:**

- 1) Intertwine the green and black wires from TR2 and connect their ends to the output jack with black to the tip lug and green to the sleeve lug.
- 2) Connect the black wire from TR1 to the fuse holder's outer solder lug. Prop this lug slightly away from the fuse holder's plastic body and plan for a little slack before cutting.

### **Insert and connect the power cord:**

- 1) Install the grommet with ¼" center into the rear chassis hole.
- 2) Gently insert the power cord through this grommet hole until at least 18" (1.5 FT) are through. Tie a knot at the end of the cord so that 1" of black outside insulation extends past the knot. This knot will serve as a strain relief. Pull the knot as tight as possible by hand. Gently pull the cord back through the grommet from outside of the chassis until the knot is snug against the inside face of the grommet.
- 3) Connect the power cord's black wire to the central lug on the fuse holder.
- 4) Connect the power cord's green wire to T2(1).
- 5) Connect the power cord's white wire to power switch lug 4 (see **Drawing 8**).

### **SECTION 6 – Connect the Tube Filament Wiring**

**Drawing 8** shows the inside chassis view with the filament wiring connected. Use the green wire for these connections and try to follow the wiring path in the drawing.

#### **Connect the filament wires from lamp holder to V2:**

- 1) Cut two pieces of green wire (about 8.5" each) and connect one end of each to the lamp holder solder lugs.
- 2) Intertwine these two wires and fasten, but **do not solder**, one wire to V2(4) and the other to V2(5).

#### **Connect the filament wires from V2 to V1:**

- 3) Cut two more pieces of green wire (about 5.5" each) and connect one wire's end to V2(4) and the other wire's end to V2(5). Now, solder all connections at V2(4) and V2(5).
- 4) Twist these two wires together and connect one wire to V1(9) and the other wire to both V1(4) and V1(5).

### **SECTION 7 – Finishing Up**

#### **Double check your work:**

1) At this point, most people will feel anxious to start playing through their amp; however, it's important to double check your work before applying power. Everyone makes mistakes and it's easy to forget things. Take some time now to thoroughly double check your work with **Drawing 8**. Make sure all solder connections are sturdy and that the polarized components are connected the right way.

#### **Attach the chassis cover and rubber bumpers:**

- 1) Use the four self-tap screws to fasten the chassis cover onto the amp.
- 2) Remove the four rubber bumpers from their backing and stick them to the cover plate to serve as feet. A good place to put them would be near each self-tap screw.

#### **Put the tubes in their sockets:**

- 1) Flip the amp over and place the tubes into their respective sockets. The EL84 goes in V2 with the retainer holding it down.
- 2) The 12AX7/ECC803 goes in the V1 socket with the tube shield holding it down.



### **Plug it in, turn it on and play!**

The MOD 102 has a single-ended (class A), cathode biased output stage. There is no need to check the bias, just plug the amp in, connect the output to a proper 8 ohm load, let the tubes heat up on standby for at least 30 seconds and it's ready to play.

Remember, once the amp has been turned on, there will be high voltage (about 250 VDC) on the filter caps. If the amp has been assembled correctly, it takes about 2 ½ minutes for the voltage on these caps to drain to less than 1 VDC after power is turned off.

Always use the one hand rule when working on an amp that has been plugged in (see page 5).

Visit [www.modkitsdiy.com](http://www.modkitsdiy.com) and e-mail [info@modkitsdiy.com](mailto:info@modkitsdiy.com) if you have any problems when first turning on your amp for troubleshooting help. ***If you smell or see smoke, hear something pop, or the chassis becomes too hot to touch, turn off power and unplug immediately.***

## Label Mounting Instructions

The labels are meant to be placed over their respective chassis holes indicated below. There are four labels for the front panel and two labels for the rear panel.

*Tip: For longer lasting labels with a plexi-like appearance, add a transparent lamination over the front of the labels by covering them with clear packing tape prior to cutting the labels.*

### Cutting the Circle

Each circle on the labels is sectioned into eight pieces to help you cut out a nice circular shape for placement over its respective chassis hole.

- 1) Use a razor or x-acto knife to cut along each line first.
- 2) Then cut along the circumference, section by section, removing one sectional piece at a time.

