

(K-MOD101) TROUBLESHOOTING SUPPLEMENT

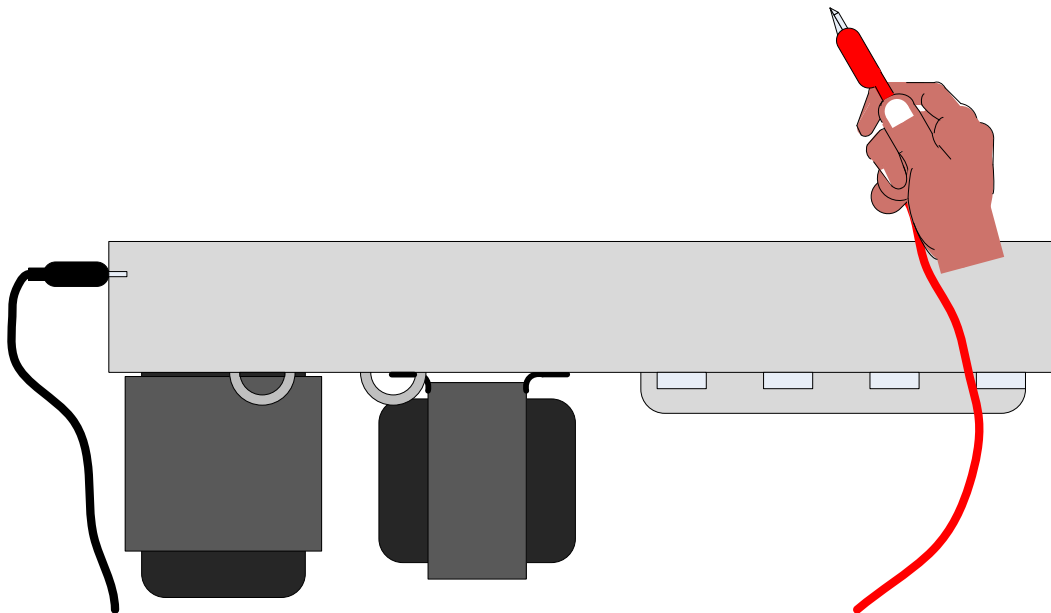

A

With 6L6GC's installed, use this supplement to help:

- Measure voltage test points to identify major discrepancies and locate problem areas.

(Keep in mind that the voltage measurements will vary slightly from amp to amp. The voltages you measure should be in the same ballpark, but do not expect to get the exact same value.)



www.modampkits.com

SAFETY

Tube amps operate at high voltages that have the potential to injure and kill. Please remember the following when troubleshooting this project.

- Only work on the amp when you are wide awake and sober.
- Do not plug the amp in until you have gone through all of the instructions, checking and re-checking each step.
- Do not turn the amp on until you have connected it to a speaker cabinet or dummy load.
- Be aware that tubes become very hot when the amp is on and can take up to 10 minutes to cool down after power is turned off.
- Always follow the one hand rule when working with an amp that is connected to power or may have voltage present. *(Any amp that has been plugged in at one time, may have high voltage present).*

The one hand rule (pictured below): is a safety precaution for working on an amp that is plugged in or could potentially have high voltages present. Using alligator clips with your DMM, clip the ground side to the chassis and use the other side to probe at various test points with one hand. *This prevents a fatal shock which can result from current passing through the heart.* *(Many people even put their other hand in their pocket or behind their back).*

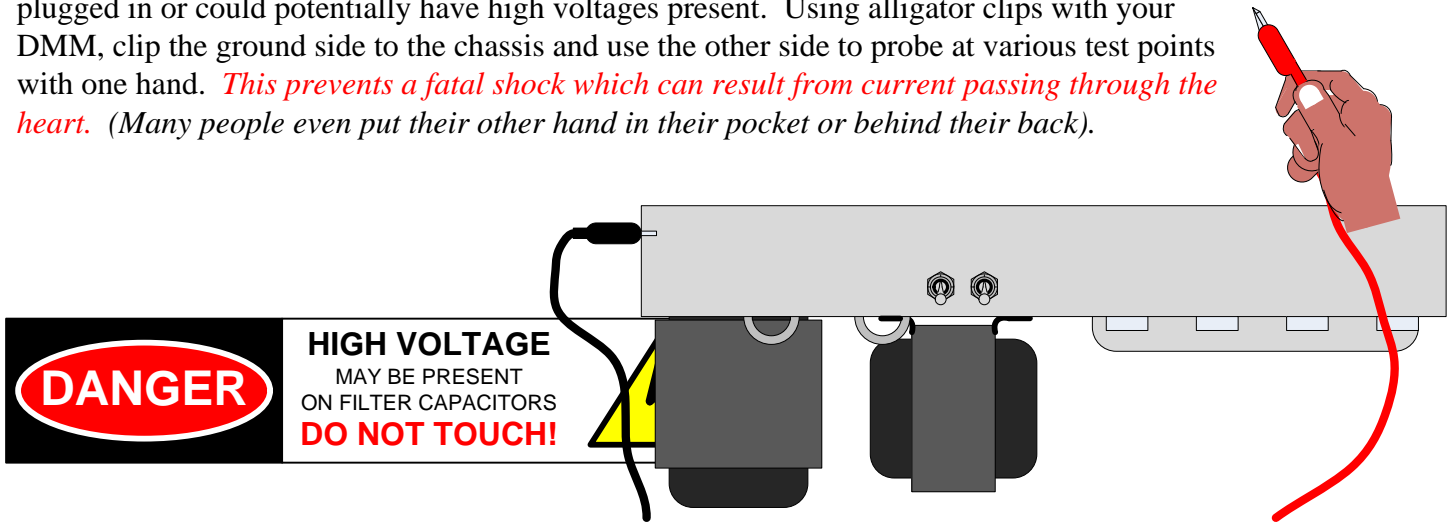

Test point sections included in this supplement include:

	Page
FILTER SECTION (TOP)	3
FILTER SECTION (INSIDE)	4
POWER TUBE BIAS SUPPLY	5
PREAMP TUBE ELECTRODES	6
POWER TUBE ELECTRODES	6
POWER SWITCH FUNCTIONALITY / CONTINUITY CHECK	7

Test Point	DC Voltage	AC Voltage
"HV"	521 VDC	2 VAC
"B"	492 VDC	0 VAC
"C"	478 VDC	0 VAC
"D"	482 VDC	0 VAC
"E"	468 VDC	0 VAC
"V3 cathode"	34.6 mVDC	0 VAC

Voltages measured from test point to ground with **no signal, bias pot turned all the way to cold** and the following front panel settings:

POWER: ON
 STANDBY: (UP POSITION)
 BASS: "0"
 TREBLE: "0"
 VOLUME: "0"

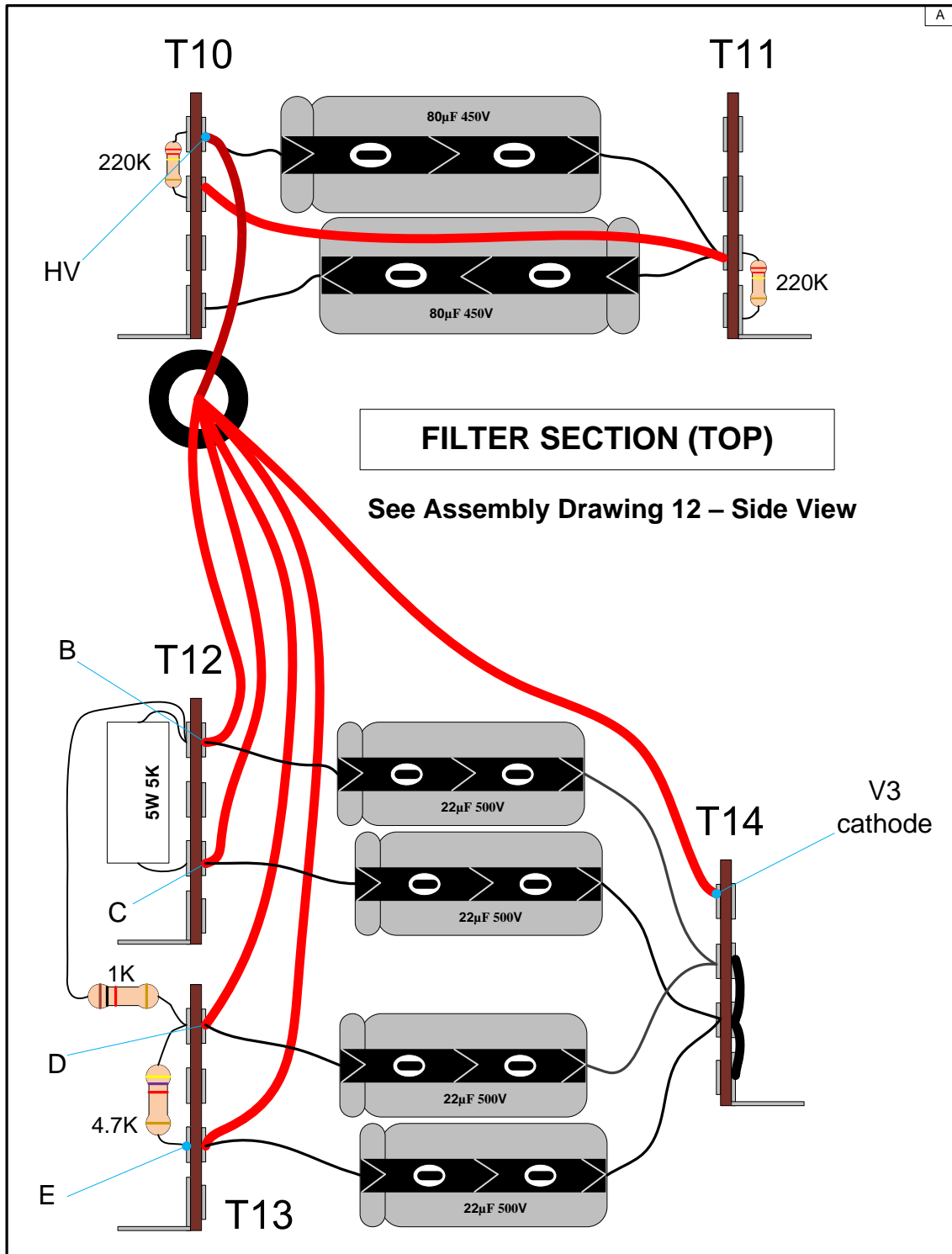

FILTER SECTION (INSIDE)

Test Point	DC Voltage	AC Voltage
"HV"	521 VDC	2 VAC
"B"	492 VDC	0 VAC
"C"	478 VDC	0 VAC
"D"	482 VDC	0 VAC
"E"	468 VDC	0 VAC
"V3 cathode"	34.6 mVDC	0 VAC

Voltages measured from test point to ground with **no signal, bias pot turned all the way to cold** and the following front panel settings:

- POWER: ON
- STANDBY: (UP POSITION)
- BASS: "0"
- TREBLE: "0"
- VOLUME: "0"

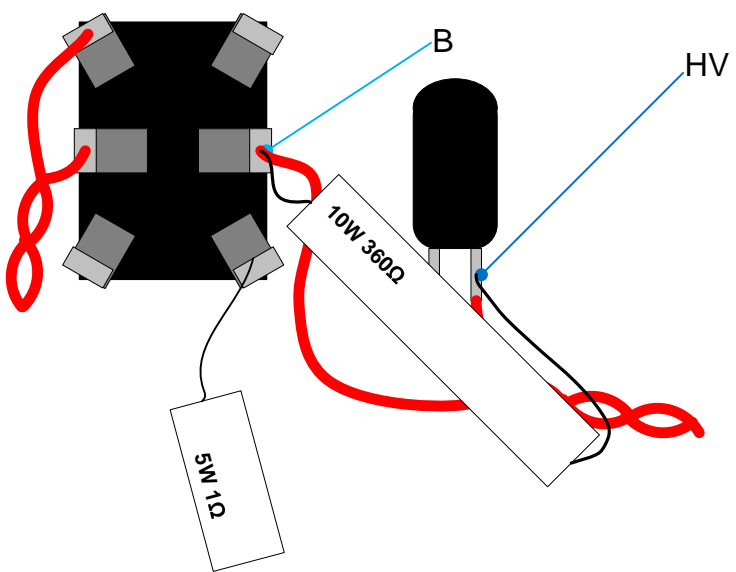

See Assembly Drawing 15

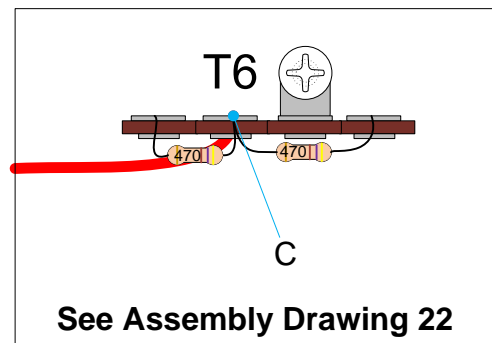

See Assembly Drawing 22

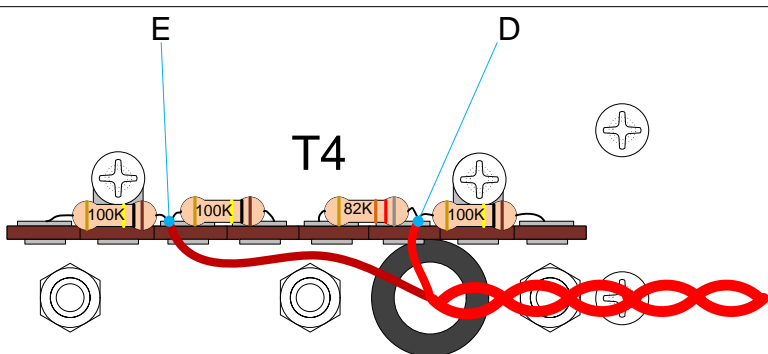

See Assembly Drawing 22

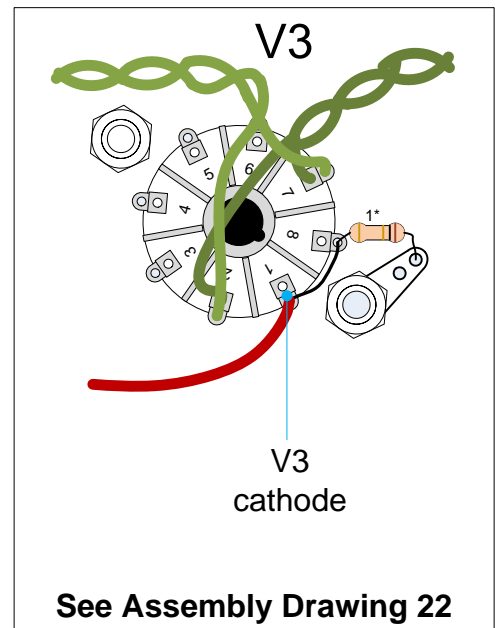

See Assembly Drawing 22

POWER TUBE BIAS SUPPLY

A

See Assembly Drawing 22

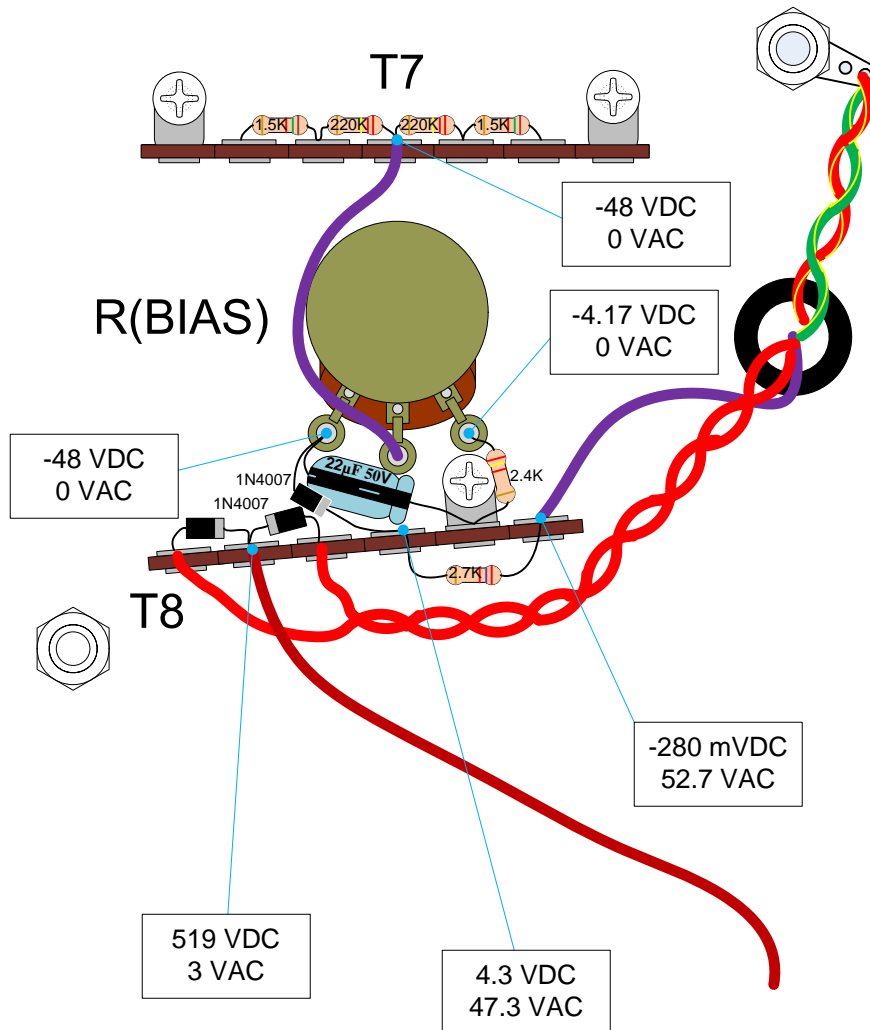

Voltages measured from test point to ground with **no signal, bias pot turned all the way to cold** and the following front panel settings:

- POWER: ON
- STANDBY: (UP POSITION)
- BASS: "0"
- TREBLE: "0"
- VOLUME: "0"

PREAMP TUBE ELECTRODES

See Assembly Drawing 22

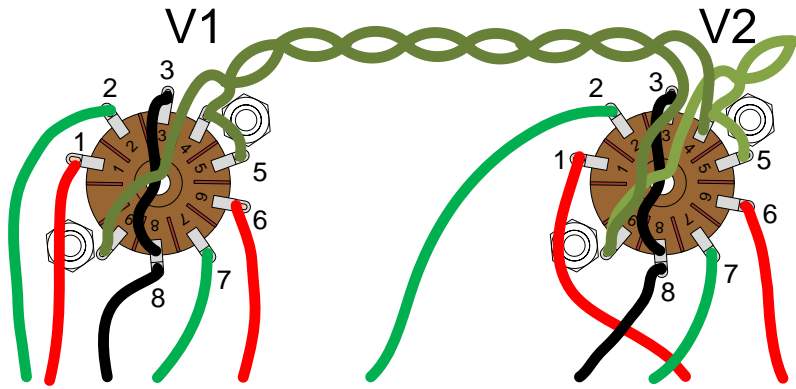

Voltages measured from test point to ground with **no signal, bias pot turned all the way to cold** and the following front panel settings:

POWER: ON
 STANDBY: (UP POSITION)
 BASS: "0"
 TREBLE: "0"
 VOLUME: "0"

Test Point	Name	DC Voltage	Test Point	Name	DC Voltage
V1 (pin 1)	V1 plate 1	328 VDC	V2 (pin 1)	V2 plate 1	276 VDC
V1 (pin 2)	V1 grid 1	0 VDC	V2 (pin 2)	V2 grid 1	68 VDC
V1 (pin 3)	V1 cathode 1	2.4 VDC	V2 (pin 3)	V2 cathode 1	106 VDC
V1 (pin 6)	V1 plate 2	320 VDC	V2 (pin 6)	V2 plate 2	254 VDC
V1 (pin 7)	V1 grid 2	0 VDC	V2 (pin 7)	V2 grid 2	73 VDC
V1 (pin 8)	V1 cathode 2	2.4 VDC	V2 (pin 8)	V2 cathode 2	106 VDC

POWER TUBE ELECTRODES

See Assembly Drawing 22

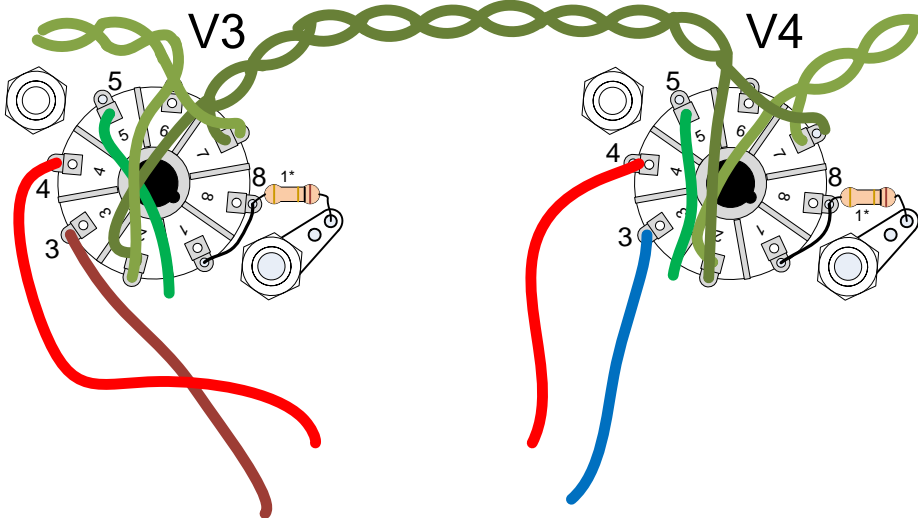

Voltages measured from test point to ground with **no signal, bias pot turned all the way to cold** and the following front panel settings:

POWER: ON
 STANDBY: (UP POSITION)
 BASS: "0"
 TREBLE: "0"
 VOLUME: "0"

Test Point	Name	DC Voltage	Test Point	Name	DC Voltage
V3 (pin 3)	V3 plate	483 VDC	V4 (pin 3)	V4 plate	487 VDC
V3 (pin 4)	V3 screen grid	470 VDC	V4 (pin 4)	V4 screen grid	471 VDC
V3 (pin 5)	V3 control grid	-47 VDC	V4 (pin 5)	V4 control grid	-46 VDC
V3 (pin 8)	V3 cathode	34 mVDC	V4 (pin 8)	V4 cathode	36 mVDC

POWER SWITCH FUNCTIONALITY / CONTINUITY CHECK

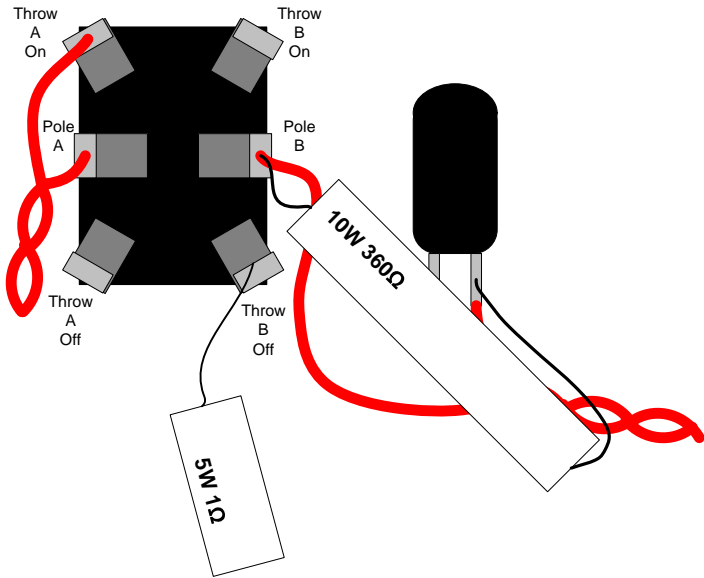

See Assembly Drawing 15

Measure continuity with the amplifier **unplugged**.

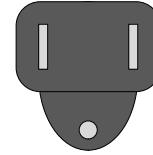

UNPLUG

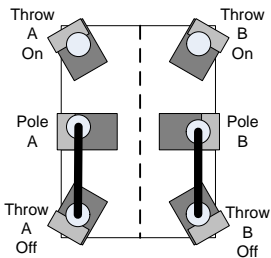

DPDT Power Switch
(OFF POSITION)

Switch Position

Measure Between

Continuity?

OFF	Pole A and Throw A Off	Yes
OFF	Pole A and Throw A On	No
OFF	Pole B and Throw B Off	Yes
OFF	Pole B and Throw B On	No

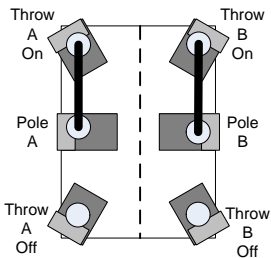

DPDT Power Switch
(ON POSITION)

Switch Position

Measure Between

Continuity?

ON	Pole A and Throw A Off	No
ON	Pole A and Throw A On	Yes
ON	Pole B and Throw B Off	No
ON	Pole B and Throw B On	Yes